

Reference manual
Marine Temperatur Calibrator
Jofra MTC-140/320/650 A



Reference Manual

Temperature Calibrator

MTC-140/320/650 A

© Copyright 2001 AMETEK Denmark A/S



About this manual....

- **The structure of the manual**

This reference manual is aimed at users who are familiar with AMETEK calibrators, as well as those who are not. The manual is divided into 11 chapters which describe how to set up, operate, service and maintain the calibrator. The technical specifications are described and accessories may be ordered from the list of accessories.

- **Safety symbols**

This manual contains a number of safety symbols designed to draw your attention to instructions which must be followed when using the instrument, as well as any risks involved.



Warning

Conditions and actions, which may compromise the safe use of the instrument and result in considerable personal injury or material damage.



Caution...

Conditions and actions, which may compromise the safe use of the instrument and result in slight personal or material damage.



Note...

Special situations which demand the user's attention.

List of contents

1.0	Introduction	4
1.1	Warranty	5
2.0	Safety instructions	6
3.0	Setting up the calibrator	11
3.1	Receipt of the calibrator	11
3.2	Preparing the calibrator.....	13
3.3	Choice of insertion tube	15
3.4	Inserting the sensor	17
4.0	Operating the calibrator.....	20
4.1	Keyboard, display and connections	20
4.2	Starting the calibrator	23
4.3	Selecting the set-temperature.....	23
4.4	Using the SWITCH TEST	25
4.5	Using the AUTO STEP	29
4.6	Using the MENU	32
4.6.1	Adjusting the temperature unit	33
4.6.2	Adjusting the max-temperature.....	34
4.6.3	Adjusting the SWITCH TEST slope rate.....	34
4.6.4	Adjusting the extra stability time.....	35
4.6.5	Adjusting the temperature resolution	35
4.7	Simulation/training	36
5.0	Storing and transporting the calibrator	37
6.0	Errors	40
7.0	Setting the mains voltage and replacing the fuses	42
7.1	Returning the calibrator for service	43
8.0	Maintenance	45
8.1	Cleaning.....	45
8.2	Adjusting and calibrating the instrument.....	47
8.2.1	Adjusting the calibration date	49
8.2.2	Calibrating/adjusting the instrument.....	50
9.0	Technical specifications	54
10.0	List of accessories.....	61
11.0	Standard insertion tubes	63

1.0 Introduction

Congratulations on your new AMETEK JF Instruments MTC-Calibrator!

With the AMETEK JF Instruments calibrator, you have chosen an extremely effective instrument which we hope will live up to all your expectations. Over the past many years, we have acquired extensive knowledge of industrial temperature calibration. This expertise is reflected in our products which are all designed for daily use in an industrial environment. Please note that we would be very interested in hearing from you if you have any ideas or suggestions for changes to our products.

This reference manual applies to the following instruments:

- **MTC-140 A (with RS232)**
- **MTC-320 A (with RS232)**
- **MTC-650 A (with RS232)**

ISO-9001 certified

AMETEK Denmark A/S was ISO-9001 certified in September 1994 by Bureau Veritas Certification Denmark.

CE-label



Your new temperature calibrator bears the CE label and conforms to the Electromagnetic Compatibility (EMC) Directive 2014/30/EU and the Low Voltage Directive 2014/35/EU and RoHS Recast (RoHS II) Directive 2011/65/EU*.

* MTC-140 A from serial no. xxxxxx-00167, MTC-320 A from serial no. xxxxxx-00262 and MTC-650 A from serial no. xxxxxx-02508

Technical assistance

Please contact the dealer from whom you acquired the instrument if you require technical assistance.

1.1 Warranty

This instrument is warranted against defects in workmanship, material and design for two (2) years from date of delivery to the extent that AMETEK will, at its sole option, repair or replace the instrument or any part thereof which is defective, provided, however, that this warranty shall not apply to instruments subjected to tampering or, abuse, or exposed to highly corrosive conditions.

THIS WARRANTY IS IN LIEU OF ALL OTHER WARRANTIES WHETHER EXPRESS OR IMPLIED AND AMETEK HEREBY DISCLAIMS ALL OTHER WARRANTIES, INCLUDING, WITHOUT LIMITATION, ANY WARRANTY OF FITNESS FOR A PARTICULAR PURPOSE OR MERCHANTABILITY. AMETEK SHALL NOT BE LIABLE FOR ANY INCIDENTAL OR CONSEQUENTIAL DAMAGES, INCLUDING, BUT NOT LIMITED TO, ANY ANTICIPATED OR LOST PROFITS.

This warranty is voidable if the purchaser fails to follow any and all instructions, warnings or cautions in the instrument's Reference Manual.

If a manufacturing defect is found, AMETEK will replace or repair the instrument or replace any defective part thereof without charge; however, AMETEK's obligation hereunder does not include the cost of transportation, which must be borne by the customer. AMETEK assumes no responsibility for damage in transit, and any claims for such damage should be presented to the carrier by the purchaser.

2.0 Safety instructions



Read this manual carefully before using the instrument!

Please follow the instructions and procedures described in this manual. They are designed to allow you to get the most out of your calibrator and avoid any personal injuries and/or damage to the instrument.



Disposal – WEEE Directive

These calibrators contain Electrical and Electronic circuits and must be recycled or disposed of properly (in accordance with the WEEE Directive 2012/19/EU).



Warning

About the use:

- The calibrator **must not** be used for any purposes other than those described in this manual, as it might cause a hazard.
- The calibrator has been designed for **indoor use only** and is not to be used in wet locations.
- The calibrator is **not to be used in hazardous areas**, where vapour or gas leaks, etc. may constitute a danger of explosion.
- The calibrator is **not** designed for operation in altitudes above 2000 meters.
- The calibrator is a CLASS I product and must be connected to a mains outlet with a protective earth connection. Ensure the ground connection of the calibrator is properly connected to the protective earth before switching on the calibrator. Always use a mains power cable with a mains plug that connects to the protective earth.

- To ensure the connection to protective earth any extension cord used **must** also have a protective earth conductor.
- Only use a mains power cord with a current rating as specified by the calibrator and which is approved for the voltage and plug configuration in your area.
- Before switching on the calibrator make sure that it is set to the voltage of the mains electricity supply.
- **Always** position the calibrator to enable easy and quick disconnection of the power source (mains inlet socket).
- The calibrator **must** be kept clear within an area of 20 cm on all sides and 1 metre above the calibrator due to fire hazard.
- **Never** use heat transfer fluids such as silicone, oil, paste, etc. in the dry-block calibrators. These fluids may penetrate the calibrator and cause electrical hazard, damage or create poisonous fumes.
- The calibrator **must** be switched off before any attempt to service the instrument is made. There are no user serviceable parts inside the calibrator.
- When cleaning the well or the insertion tube, **REMEMBER** to wear goggles when using compressed air!

About the frontpanel:

- The connectors, on the front panel of the calibrator, must **NEVER** be connected to a voltage source.
- Thermostats must **not** be connected to any other voltage source during a test.

About insertion tubes and insulation plugs:

- **Never** leave hot insertion tubes which have been removed from the calibrator unsupervised – they may constitute a fire hazard or personal injury.
If you intend to store the calibrator in the aluminium carrying case after use, you **must** ensure that the instrument has cooled to a temperature **below**

100°C/212°F before placing it in the carrying case.

- **Never** place a hot insertion tube in the optional carrying case.
- Use only insulation plugs supplied by AMETEK Denmark A/S.

About the fuses:

- The fuse box must not be removed from the power control switch until the mains cable has been disconnected.
- The two main fuses must have the specified current and voltage rating and be of the specified type. The use of makeshift fuses and the short-circuiting of fuse holders are prohibited and may cause a hazard.



Caution – Hot surface

This symbol is engraved in the grid plate.



- **Do not touch** the grid plate, the well or the insertion tube as the calibrator is heating up – they may be very hot and cause burns.
- **Do not touch** the tip of the sensor when it is removed from the insertion tube/well – it may be very hot and cause burns.
- **Do not touch** the handle of the calibrator during use – it may be very hot and cause burns.
- **Over 50°C/122°F**
If the calibrator has been heated up to temperatures above 50°C/122°F, you must wait until the instrument reaches a temperature **below 50°C/122°F** before you switch it off.
- **Do not** remove the insert from the calibrator before the insert has cooled down to less than 50°C/122°F



Caution – Cold surface

Below 0°C/32°F (applies only to the MTC-140 A model)

- If the calibrator has reached a temperature below 0°C/32°F, ice crystals may form on the insertion tube and the well. This, in turn, may cause verdigris to form on the material.

To prevent this from happening, simply heat up the calibrator to 100°C/212°F and any water left will evaporate.

Remove the insulation plug while heating up.

It is very important that humidity in the well and insertion tube is removed to prevent corrosion and frost expansion damages.

- **Do not** touch the well or insertion tube when these are below 0°C/32°F - they might create frostbite.



Caution...

About the use:

- **Do not** use the instrument if the fan is out of order.
- Before cleaning the calibrator, you **must** switch it off, allow it to cool down and remove all cables.

About the well, insertion tube and grid plate:

- The well and the insertion tube **must** be clean before use.
- **Do not** pour any form of liquids into the well. It might damage the well.
- Scratches and other damage to the insertion tubes should be avoided by storing the insertion tubes carefully when not in use.
- The insertion tube must **never** be forced into the well. The well could be damaged as a result, and the insertion tube may get stuck.
- **Before** using new insertion tubes for the calibration,

the insertion tubes **must** be heated up to maximum temperature - 320°C (608°F) / 650°C (1202°F) - for a period of minimum 30 minutes.

The insertion tube must **always** be removed from the calibrator after use.

The humidity in the air may cause corrosion oxidation on the insertion tube inside the instrument. There is a risk that the insertion tube may get stuck if this is allowed to happen.

- If the calibrator is to be transported, the insertion tube **must** be removed from the well to avoid damage to the instrument.



Note...

The product liability **only** applies if the instrument is subject to a manufacturing defect. This liability becomes void if the user fails to follow the maintenance instructions set out in this manual or uses unauthorised spare parts.

3.0 Setting up the calibrator

3.1 Receipt of the calibrator

The calibrator is supplied in an aluminium carrying case.

When you receive the instrument...

- Carefully unpack and check the calibrator and the accessories.
- Check the parts off against the list shown below.

If any of the parts are missing or damaged, please contact the dealer who sold the calibrator.

You should receive:

- 1 calibrator
-

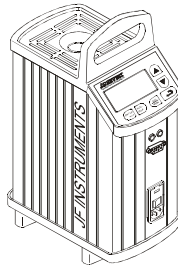

- 1 mains cable
-

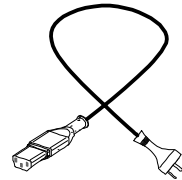

- 1 set of test cables (1 black, 1 red)
-



- 3 pcs. insulation plugs for 6, 10, 13 mm sensors (MTC-140 A only)
-

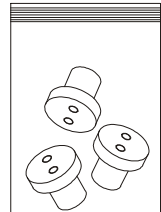

- 1 insertion tube (user specified)
-

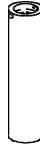

- 1 tool for insertion tube
-

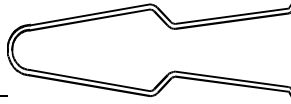

- 1 traceable certificate
-

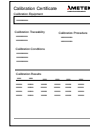

- 1 RS 232 serial cable
-

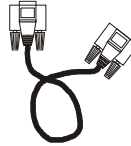

- 1 USB-key containing reference manual and software package “JOFACAL”.
-

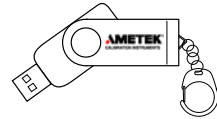

When reordering, please specify the parts number found in the list of accessories, section 10.0.

3.2 Preparing the calibrator



Warning

- The calibrator has been designed for **indoor use only** and is not to be used in wet locations.
- The calibrator is **not to be used in hazardous areas**, where vapour or gas leaks, etc. may constitute a danger of explosion.
- The calibrator is **not** designed for operation in altitudes above 2000 meters.
- The calibrator is a CLASS I product and must be connected to a mains outlet with a protective earth connection. Ensure the ground connection of the calibrator is properly connected to the protective earth before switching on the calibrator. Always use a mains power cable with a mains plug that connects to the protective earth.
- To ensure the connection to protective earth any extension cord used **must** also have a protective earth conductor.
- Only use a mains power cord with a current rating as specified by the calibrator and which is approved for the voltage and plug configuration in your area.
- Before switching on the calibrator make sure that it is set to the voltage of the mains electricity supply.
- **Always** position the calibrator to enable easy and quick disconnection of the power source (mains inlet socket).
- The calibrator **must** be kept clear within an area of 20 cm on all sides and 1 metre above the calibrator due to fire hazard.



Note...

The instrument must **not** be exposed to draughts.

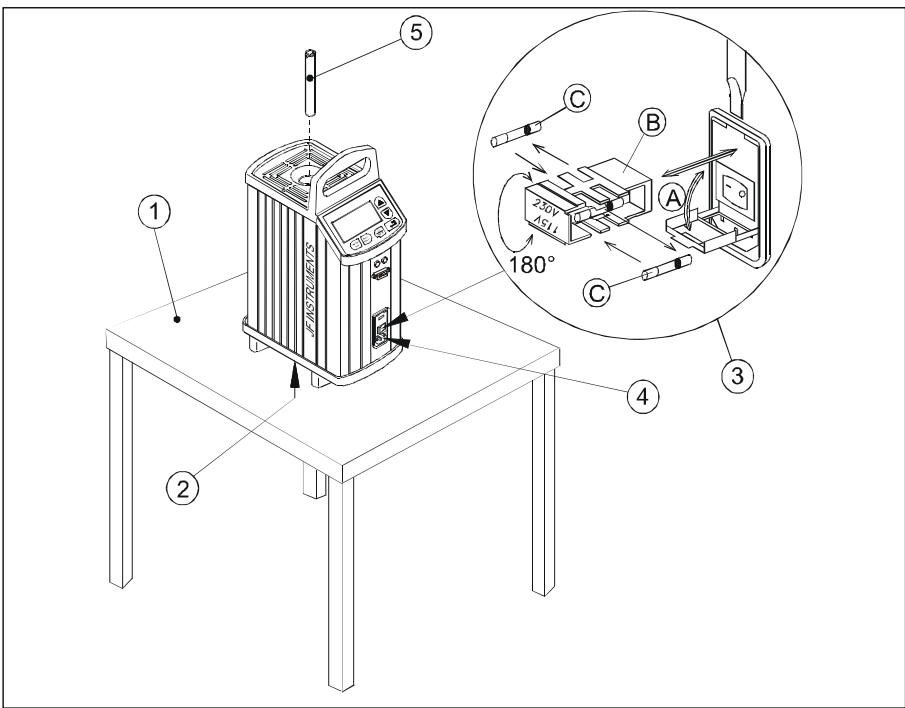

Fig. 1

When setting up the calibrator, you must...

- ① place the calibrator on an even horizontal surface in the spot you intend to use it.



Caution...

Do not use the instrument if the fan is out of order.

- ② ensure a free supply of air to the fan located at the bottom of the instrument.
- ③ check the voltage of the power control switch (on/off switch (230V/115V)). If the voltage of the power control switch differs from the line voltage, you must adjust the voltage of the power control switch as follows (see Fig. 1):



Warning

The two main fuses must have the specified current and voltage rating and be of the specified type. The use of makeshift fuses and the short-circuiting of fuse holders are prohibited and may cause a hazard.

- A. Open the fuse box lid using a screwdriver.
 - B. Take out the fuse box.
 - C. Remove both fuses and insertion tube two new fuses. These must be identical and should correspond to the line voltage. See section 10.0.
 - B. Turn the fuse box 180° and slide it into place.
- ④ check that the earth connection for the instrument is present and attach the cable.
- ⑤ select an insertion tube with the correct bore diameter. See section 3.3 for information on how to select insertion tubes.

The calibrator is now ready for use.

3.3 Choice of insertion tube



Caution...

Before using new insertion tubes for the calibration, the insertion tubes **must** be heated up to maximum temperature - 320°C (608°F) / 650°C (1202°F) - for a period of minimum 30 minutes.



Caution...

To get the best results out of your calibrator, the insertion tube dimensions, tolerance and material are critical. We highly advise using the JOFRA insertion tubes, as they guarantee trouble free operation. Use of other insertion tubes may reduce performance of the calibrator and cause the insertion tube to get stuck.

Insertion tubes are selected on the basis of the diameter of the sensor to be calibrated.

Use the table for insertion tubes in section 10.0 to find the correct parts number.

Alternatively, you may order an undrilled insertion tube and drill the required hole yourself. The finished dimension should be as follows:

- Sensor diameter $+0.2 \text{ } +0.05/-0 \text{ mm}$.

3.4 Inserting the sensor

Before inserting the sensor and switching on the calibrator, please note the following important warning:



Warning

- **Never** use heat transfer fluids such as silicone, oil, paste, etc.
These fluids may penetrate the calibrator and cause electrical hazard, damage or create poisonous fumes.
- Use only insulation plugs supplied by AMETEK Denmark A/S.



Caution...

- The well and the insertion tube **must** be clean before use.
- **Do not** pour any form of liquids in the well. It might damage the well.
- Scratches and other damage to the insertion tubes should be avoided by storing the insertion tubes carefully when not in use.
- The insertion tube must **never** be forced into the well. The well could be damaged as a result, and the insertion tube may get stuck.



Caution – Hot surface

- **Do not touch** the grid plate, the well or the insertion tube as the calibrator is heating up – they may be very hot and cause burns.
- **Do not touch** the tip of the sensor when it is removed from the insertion tube/well – it may be very hot and cause burns.
- **Do not touch** the handle of the calibrator during use – it may be very hot and cause burns.

Insert the sensor as shown in Fig. 2.

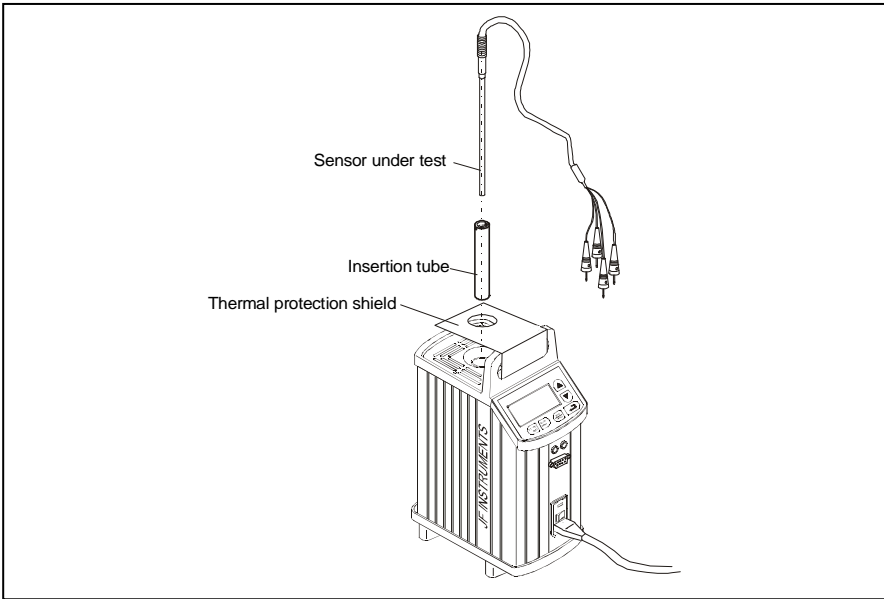

Fig. 2

In order to spare the sensor and its connections it is recommended to use a heat protection shield (104216) at high temperatures.

For MTC-140 A only.

Check that the insulation plug fits the diameter of the sensor. Otherwise replace it.

If the design of the sensor permits it, you are advised to use an insulation tube and insulation as shown in Fig. 3.

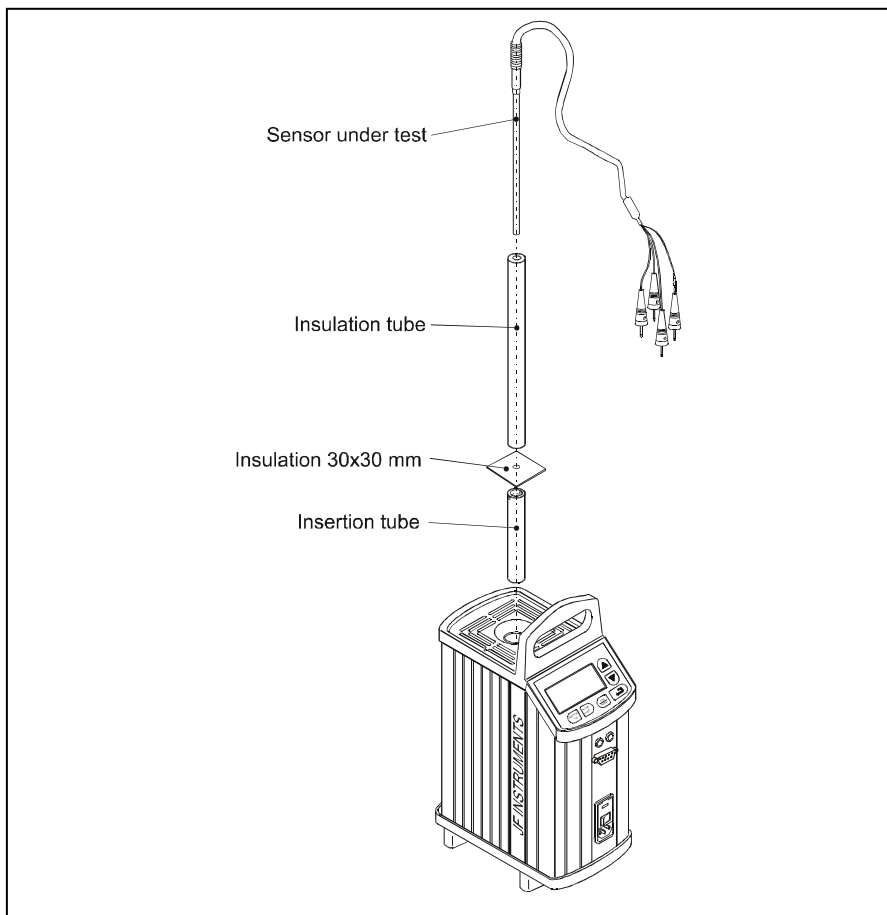

Fig. 3

4.0 Operating the calibrator

4.1 Keyboard, display and connections

Keyboard

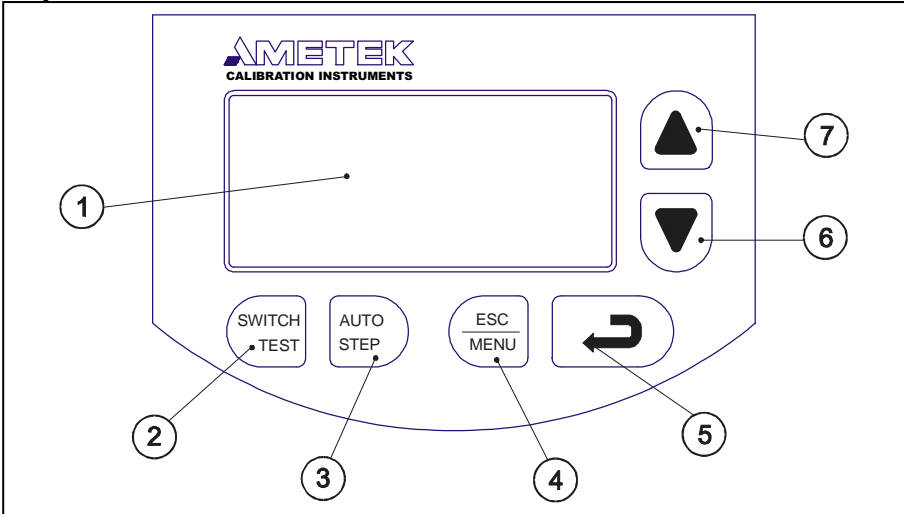

Fig. 4

Pos.	Description
------	-------------

- | | |
|---|---|
| ① | LCD. |
| ② | SWITCH TEST button used to activate SWITCH TEST. The function automatically detects the opening/closing temperatures for thermostats. |
| ③ | AUTO STEP button used to activate AUTO STEP. The function is used to switch between a series of set-temperatures automatically. |
| ④ | ESC/MENU button used as Escape key or to activate the menu system (hold button down for min. 2 seconds). |
| ⑤ | ENTER button used to accept chosen options. |
| ⑥ | DOWN ARROW button used to adjust temperature values (value decreases) and to select menu options. |

- ⑦ UP ARROW button used to adjust temperature values (value increases) and to select menu options.

Display

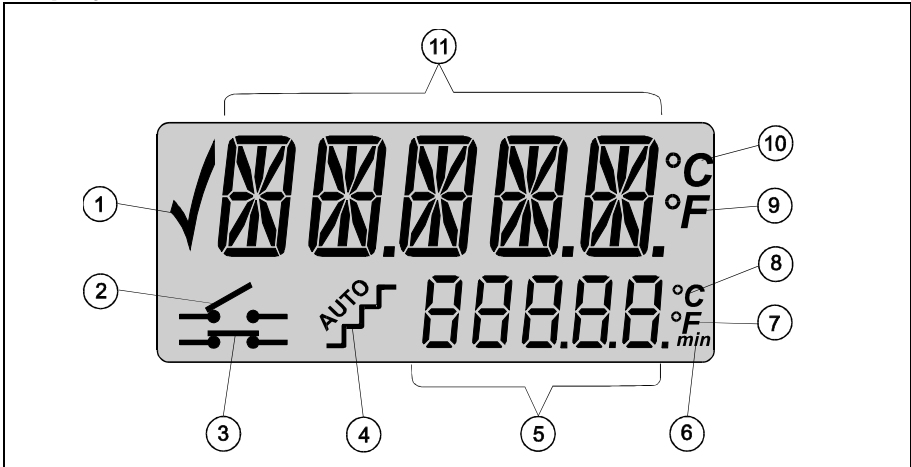

Fig. 5

Pos.	Description
------	-------------

- | | |
|---|--|
| ① | CHECKMARK displayed when the calibrator is stable. |
| ② | SWITCH TEST input open. |
| ③ | SWITCH TEST input closed. |
| ④ | AUTO STEP symbol used to indicate that the function is active (symbol flashes repeatedly). |
| ⑤ | Used to display set-temperatures, time-until-stable and parameter values in the menu system. |
| ⑥ | Minute time unit for bottom display. |
| ⑦ | Fahrenheit temperature unit for bottom display. |
| ⑧ | Celsius temperature unit for bottom display. |
| ⑨ | Fahrenheit temperature unit for top display. |

- ⑩ Celsius temperature unit for top display.
- ⑪ Used to display Read-temperature and parameters in the menu system.

Connections



Warning

- The connectors, pos. 2 on the front panel, must **NEVER** be connected to a voltage source.
- Thermostats must **not** be connected to any other voltage source during a test.

All connections are located on the front panel.

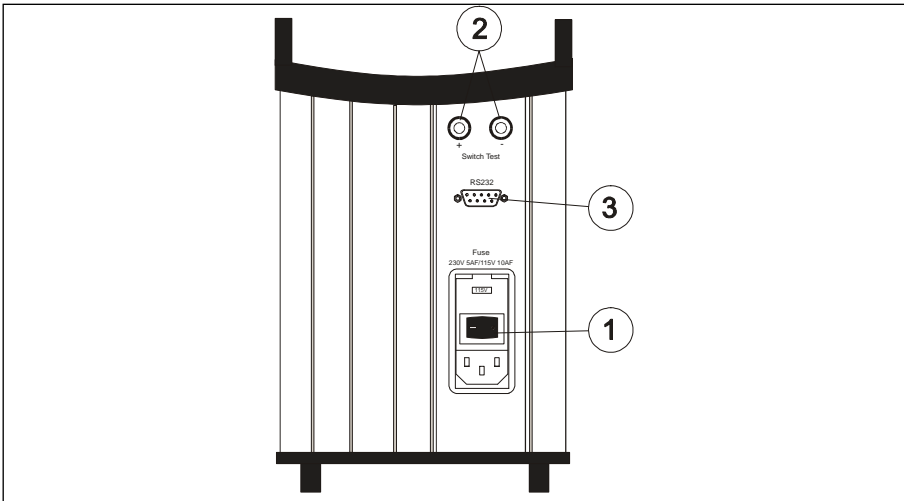

Fig. 6

Pos.	Description
------	-------------

- | | |
|---|--|
| ① | Power control switch with connection for cable and on/off switch. Also contains the main fuse. See section 7.0 for information on how to change the fuses and setting the mains voltage. |
| ② | Connection for thermostat test. |

- ③ Connection for RS232 cable.

Note that all PC-equipment, which are connected to the calibrator must observe the directive IEC950.

4.2 Starting the calibrator



Switch the calibrator on using the power control switch (pos. 1 in Fig. 6).

The instrument is initialised and the last calibration date is displayed:



The calibration date will be displayed for approx. 2 seconds. The initialisation process has been completed and the calibrator is ready for use.

All settings are stored when the calibrator is switched off. When the instrument is switched back on again, the status will be the same as when it was switched off.

4.3 Selecting the set-temperature



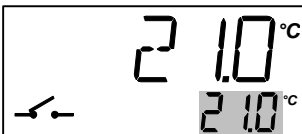

Press  or  to adjust the set-temperature.

The current selection flashes in the bottom display:



The starting point is the last chosen set-temperature (even if the instrument has been switched off).



Press  to accept the change or  to cancel.

The calibrator will now heat up/cool down.

The top display continuously shows the read-temperature.
The bottom display shows either the set-temperature or the estimated time in whole minutes until the calibrator will be stable:

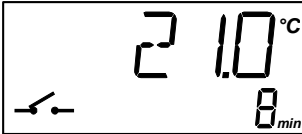

When the calibrator is stable the display will show the  checkmark symbol. The instrument will emit an audible alarm and the estimated time until stable will be replaced by the set-temperature:

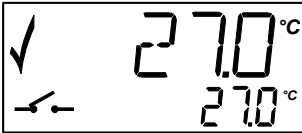

4.4 Using the SWITCH TEST

SWITCH TEST automatically locates the switch temperature of a thermostat.

You must enter a temperature range $T_{\min} - T_{\max}$, within which the switch temperature is expected to be found. You must also specify the slope rate to be used during the test in SETUP (the smaller the value, the more accurate the results of the test and the longer the test will take).

The function can be illustrated using the following example:

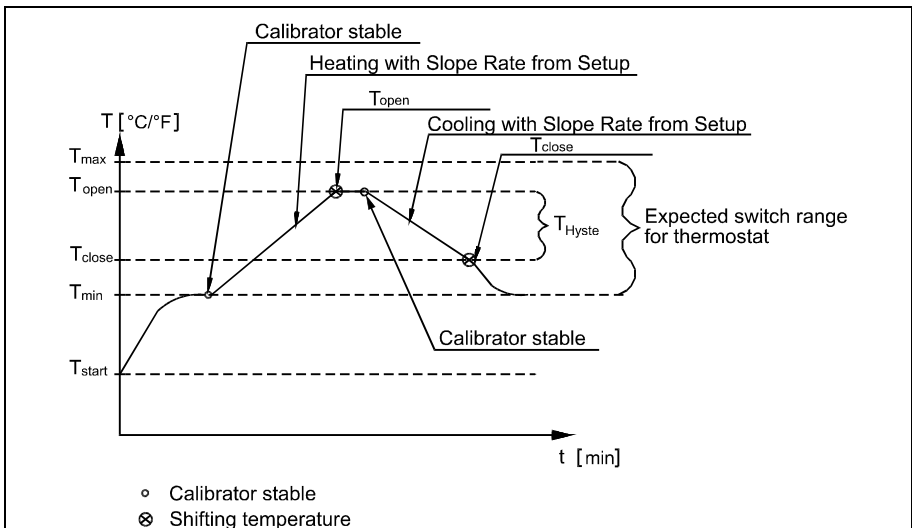



Fig. 7

Press .

The symbols  for SWITCH TEST will flash to indicate that the function is active.

The function can be cancelled at any time by pressing .

Press  or  to select the required T_{\min} :

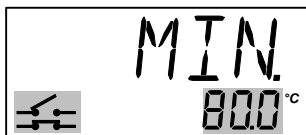

Press  to accept your selection.

Press  or  to select the required T_{\max} :

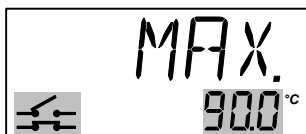

Press  to accept your selection.

The calibrator will now start working towards the T_{\min} :

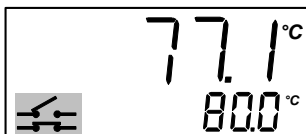

Once the T_{\min} has been reached and the calibrator is stable, the instrument will emit an audible alarm and display the status for one second:

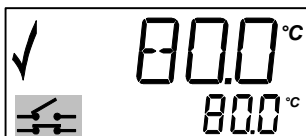

The calibrator will now start working towards the T_{max} using the slope rate selected in SETUP. The flashing SWITCH TEST symbol indicates the current status:

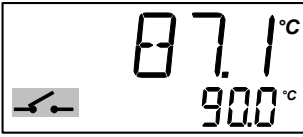

The instrument will check for changes in the SWITCH TEST. If no change has been detected by the time T_{max} is reached, the instrument will register an ERROR.

The calibrator will stabilise at this temperature, and then work towards the T_{min} using the slope rate selected in SETUP.

The flashing SWITCH TEST symbol indicates the current status:



The instrument will check for changes in the SWITCH TEST input once again. If no change has been detected by the time the T_{min} has been reached, the instrument will register an ERROR.

The results of the test will be displayed as 3 values: an “Open” temperature, a “Close” temperature and a “Hyste” hysteresis temperature (the difference between the two temperatures).

The open temperature is shown first:



Press  to display the close temperature:

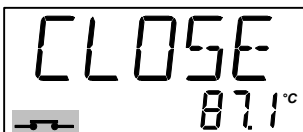



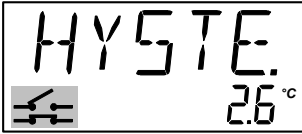

Press  to display the hysteresis temperature:



If a temperature has not been found, the instrument will display an “Error” (the “Hyste” temperature will also be shown as an “Error”):



Press  or  to end the SWITCH TEST. The instrument will store the T_{\min} and T_{\max} until the next time the SWITCH TEST is activated.



Note...

you can activate  or  during the test to display the temporary results.

4.5 Using the AUTO STEP

AUTO STEP is used to step automatically between a range of different calibration temperatures. This is useful when calibrating sensors in places which are hard to reach, and when calibrating sensors for which the output is displayed in a different location.

The function can be illustrated using the following example:

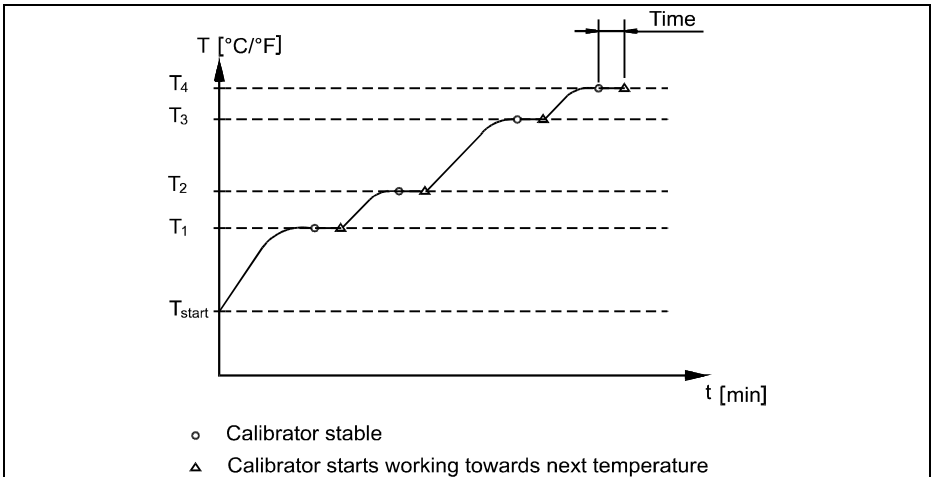





Fig. 8

Press  .



The  symbol for AUTO STEP flashes to indicate that the function is active.

The function can be cancelled at any time by pressing .

Press  or  to select the required number of steps (minimum 2 steps, maximum 9 steps):



Press  to accept your selection.

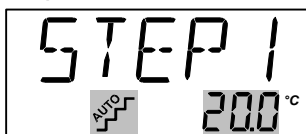

Press  or  to select the required set-temperature for step 1:



Press  to accept your selection.

Repeat the above procedure for all temperature steps.

Press  to accept your choices once you have adjusted the last temperature step.

Press  or  to set the amount of extra time you wish the calibrator to remain at every step:



Press  to accept your selection.

The following will be displayed for one second to indicate that the calibrator is ready to work towards the set-temperature:

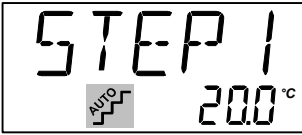

The calibrator will now work towards the given set-temperature. An audible alarm will be emitted once the calibrator is stable. The calibrator will wait the specified amount of extra time. The instrument indicates this by counting down the amount of time remaining:





The calibrator will then go to the next step. The procedure is the same as for the first step. This process will be repeated until the last step has been executed and the function has been completed.

4.6 Using the MENU

Hold down  for more than approx. 2 seconds:



Press  to select SETUP.

Press  or  to switch between the adjustable parameters:

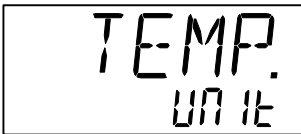

↑↓



↑↓



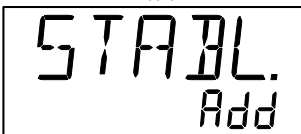

↑↓





↑↓



 If you wish to exit SETUP, simply press  .

 The instrument will ignore all changes if you press  when adjusting any of the parameters.

 Press  to adjust the parameter.

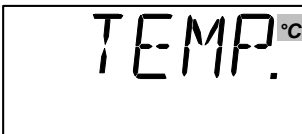

4.6.1 Adjusting the temperature unit

 Press  or  to switch between °C and °F:



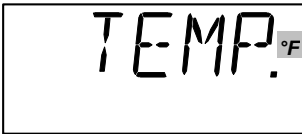

- and





 Press  to accept your selection.

4.6.2 Adjusting the max-temperature

 Press  or  to set the max-temperature in steps of 0.1°C or 0.1°F:





If the current set-temperature is higher than the new max-temperature, you will need to adjust the set-temperature. The instrument will immediately begin to cool (if required) as soon as the new max-temperature is accepted.



 Press  to accept your selection.

 If you wish to exit SETUP, simply press  .

4.6.3 Adjusting the SWITCH TEST slope rate



 Press  or  to set the SWITCH TEST slope rate to a temperature between 0.1°C and 9.9°C/minutes in steps of 0.1°C (if your chosen temperature unit is °F, the range will change to between 0.1°F and 9.9°F/minutes in steps of 0.1°F):





 Press  to accept your selection.

4.6.4 Adjusting the extra stability time

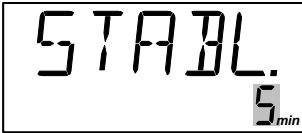

The extra stability time is the amount of extra time you wish to elapse before the checkmark symbol ✓ is displayed after the calibrator has stabilised.

 Press  or  to set the time to anywhere between 0 and 20 minutes:



 Press  to accept your selection.



4.6.5 Adjusting the temperature resolution

 Press  or  to select the required number of decimals:



- and



 Press  to accept your selection.

4.7 Simulation/training

 Hold down the  and  buttons while you switch on the calibrator.

The instrument will display the following screen:



The instrument will then revert to the standard display.

The calibrator's simulation mode is used to train personnel in the use of the instrument, etc. The simulation setting differs from the standard setting as follows:

- The instrument will not actually heat up or cool down the well.
- The heating and cooling processes are simulated at around 10 times the normal speed of these operations.

The calibrator will remain in simulation mode until it is switched off.

5.0 Storing and transporting the calibrator



Caution...

The following guidelines should always be observed when storing and transporting the calibrator. This will ensure that the instrument and the sensor remain in good working order.

Switch off the calibrator using the power control switch. Note that the calibration procedure may be interrupted at any time using the power control switch. Switching off the calibrator during the calibration process will not damage either the instrument or the sensor.

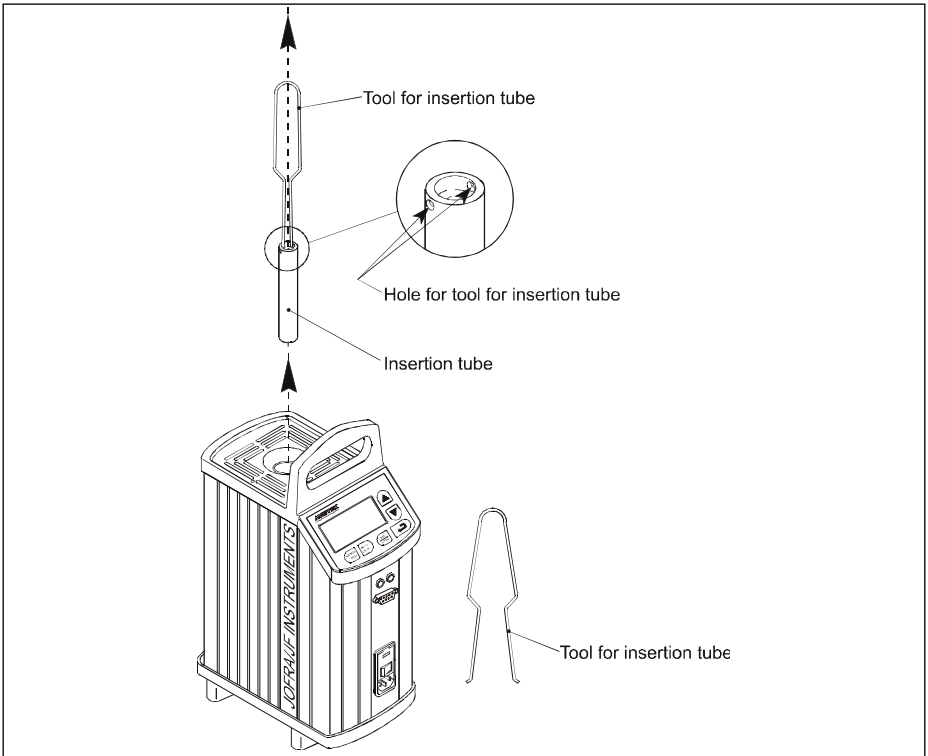

Fig. 9

The following routine must be observed **before the insertion tube is removed** and the instrument switched off:



Over 50°C/122°F

If the calibrator has been heated up to temperatures above 50°C/122°F, you must wait until the instrument reaches a temperature **below 50°C/122°F** before you switch it off.



Caution – Cold surface

Below 0°C/32°F (applies only to the MTC-140 A model)

- If the calibrator has reached a temperature below 0°C/32°F, ice crystals may form on the insertion tube and the well. This, in turn, may cause the material surfaces to oxidize

To prevent this from happening, simply heat up the calibrator to 100°C/212°F until all water left has evaporated.

Remove the insulation plug while heating up.

It is very important that humidity in the well and insertion tube is removed to prevent corrosion and frost expansion damages.

- **Do not** touch the well or insertion tube when these are below 0°C/32°F - they might create frostbite.

Remove the insertion tube from the calibrator using the tool for insertion tube supplied with the instrument as shown in Fig. 9.



Caution – Hot surface

Do not remove the insert from the calibrator before the insert has cooled down to less than 50°C/122°F.



Caution...

- The insertion tube must **always** be removed from the calibrator after use.
The humidity in the air may cause corrosion oxidation to form on the insertion tube inside the instrument. There is a risk that the insertion tube may get stuck if this is allowed to happen.
- If the calibrator is to be transported, the insertion tube **must** be removed to avoid damage to the instrument.



Warning

- **Never** leave hot insertion tubes which have been removed from the calibrator unsupervised – they may constitute a fire hazard or personal injury.

If you intend to store the calibrator in the optional aluminium carrying case after use, you **must** ensure that the instrument has cooled to a temperature **below 100°C/212°F** before placing it in the carrying case.

- **Never** place a hot insertion tube in the optional carrying case.
- **Do not** touch the well or insertion tube when these are deep frozen – they can create frostbite.

6.0 Errors



Warning

The calibrator **must** be switched off before any attempt to service the instrument is made. There are no user serviceable parts inside the calibrator.



Note...

AMETEK Denmark's liability ceases if:

- parts are replaced/repaired using spare parts which are not identical to those recommended by the manufacturer.
- non-original parts are used in any way when operating the instrument.

AMETEK Denmark's liability is restricted to errors which originated from the factory.

If the calibrator detects an error during operation, the instrument will terminate all functions and display an error code:

ERROR 0001

Likely cause: Defective RTD-sensor or excessively high temperature measured by the instrument's internal sensor.

Solution: The calibrator should be returned to the manufacturer for service.

ERROR 0002

Likely cause: The calibration coefficients have not been accepted.

Solution: Try again. If the error message returns, the calibrator should be returned to the manufacturer for service.

ERROR 0003

Likely cause: An error has occurred in the control circuit.

Solution: The calibrator should be returned to the manufacturer for service.

ERROR 0004

Likely cause: Incorrect mains frequency setting.

Solution: Mains frequency not compatible with instrument configuration.

Please contact AMETEK Denmark A/S for guidance.

Nothing happens when the power control switch (on/off switch) is pressed.

Likely cause: There is no power to the calibrator.

Solution: Check that the calibrator is correctly connected.
Check the fuse.

If there are no problems with the mains cable or the fuse, the calibrator should be returned to the manufacturer for service.

7.0 Setting the mains voltage and replacing the fuses



Warning

- The calibrator **must** be switched off before any attempt to service the instrument is made. There are no user serviceable parts inside the calibrator.
- The fuse box must not be removed from the power control switch until the mains cable has been disconnected.
- The two main fuses must have the specified current and voltage rating and be of the specified type. The use of makeshift fuses and the short-circuiting of fuse holders are prohibited and may cause a hazard.

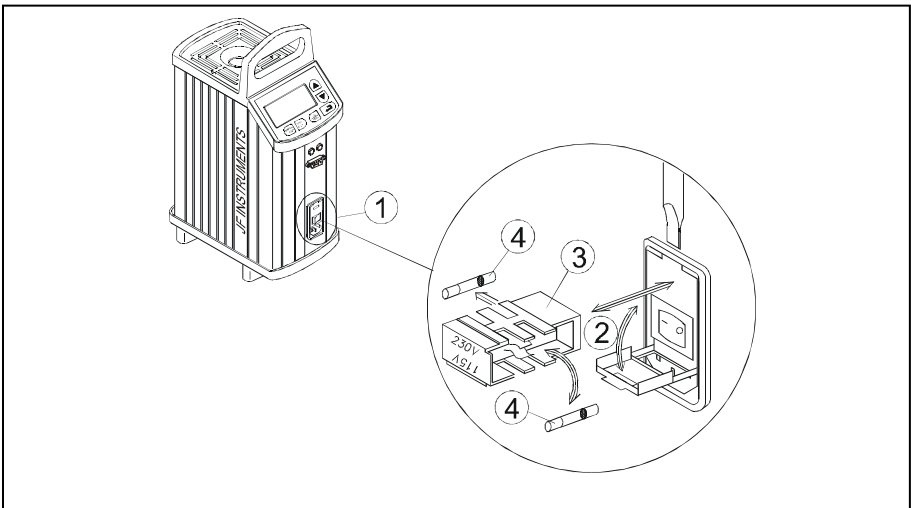

Fig. 10

- ① Locate the main fuses in the fuse box in the power control switch and check the voltage of the power control switch (on/off switch (230V/115V)). If the voltage of the power control switch differs from the line voltage, you must adjust the voltage of the power control switch.

- ② Open the lid of the fuse box using a screwdriver.
- ③ Remove the fuse box.
- ④ Remove both fuses and insert two new fuses. These must be identical and should correspond to the line voltage.
 - **MTC-140:** 115V, 2AT = 105014 / 230V, 1AT = 105007
 - **MTC-320/650:** 115V, 10AF = 60B302 / 230V, 5AF = 60B301
- ⑤ If the fuses blow immediately after you have replaced them, the calibrator should be returned to the manufacturer for service.

Slide the fuse box into place with the correct voltage turning upwards.

7.1 Returning the calibrator for service

When returning the calibrator to the manufacturer for service, please enclose a fully completed service information form. Simply copy the form on the following page and fill in the required information. The calibrator should be returned in the aluminium carrying case.

Furthermore please follow the guidelines for transportation described in chapter 5.0 – Storing and transporting the calibrator.

Service info

Customer data:**Date:**

Customer name and address: _____

Attention and Dept.: _____

Fax no./Phone no.: _____

Your order no.: _____

Delivery address: _____

Distributor name: _____

Instrument data:

Model and Serial no.: _____

Warranty claimed Yes: _____ No: _____ Original invoice no.: _____

Temp.
calibrationSensor
input**Service request:****This instrument is sent for
(please check off):**

___ Calibration as left

___ Check

___ Calibration as found and as left

___ Service

___ Accredited calibration as left

___ Repair

___ Accredited calibration as found and as left.

Diagnosis data/cause for return:

Diagnosis/Fault description: _____

Special requests: _____

Safety precautions: if the product has been exposed to any hazardous substances, it must be thoroughly decontaminated before it is returned to AMETEK. Details of the hazardous substances and any precautions to be taken must be enclosed.

8.0 Maintenance

8.1 Cleaning



Caution...

- Before cleaning the calibrator, you **must** switch it off, allow it to cool down and remove all cables.
- The insertion tube must **always** be removed from the calibrator after use.

The humidity in the air may cause corrosion oxidation in the insertion tube inside the instrument. There is a risk that the insertion tube may get stuck if this is allowed to happen.



Caution – Hot surface

Do not remove the insert from the calibrator before the insert has cooled down to less than 50°C/122°F



Warning (all versions)

- **Never** leave hot insertion tubes that have been removed from the calibrator unsupervised – they may constitute a fire hazard or personal injury.

If you intend to store the calibrator in the optional aluminium carrying case after use, you **must** ensure that the instrument has cooled to a temperature **below 100°C/212°F** before placing it in the carrying case.

- **Do not** touch the well or insertion tube when these are deep frozen – they can create frostbite.

Users should/must carry out the following cleaning procedures as and when required:

- **The exterior of the instrument** - Clean using water and a soft cloth.
The cloth should be wrung out hard to avoid any water penetrating the calibrator and causing damage.
When heavily soiled the exterior of the instrument and the keyboard can be wiped clean using isopropyl alcohol.
- **The insertion tube** - Must **always** be clean and should be regularly wiped using a soft, lint-free, dry cloth.
You must ensure there are no textile fibres on the insertion tube when it is inserted in the well. The fibres may adhere to the well and damage it.
If the calibrator has reached a temperature below 0°C/32°F, ice crystals may form on the insertion tube. This, in turn, may cause the material surfaces to oxidize (MTC-140 A only).
To prevent this from happening, the insertion tube must be dried. This is done by heating up the calibrator to min. 100°C/212°F until all water left has evaporated.
Remove the insulation plug while heating up.
It is very important that humidity in the insertion tube is removed to prevent corrosion and frost expansion damages.
- **The well** - Must **always** be clean. Dust and textile fibres should be removed from the well using e.g. compressed air.



Warning

REMEMBER! Wear goggles when using compressed air!

If the calibrator has reached a temperature below 0°C/32°F, ice crystals may form on the well. This, in turn, may cause the material surfaces to oxidize (MTC-140 A only).

To prevent this from happening, the well must be dried. This is done by heating up the calibrator to min. 100°C/212°F until all water left has evaporated.

Remove the insulation plug while heating up.

It is very important that humidity in the well is removed to prevent corrosion and frost expansion damages.

8.2 Adjusting and calibrating the instrument

You are advised to return the calibrator to AMETEK Denmark A/S or an accredited laboratory at least once a year for calibration and adjustment.

Alternatively, you can calibrate/adjust the calibrator yourself. You will need a reference thermometer and a reference sensor with a traceable certificate. Please follow the instructions given below.

Connect the calibrator to an external precision instrument (e.g. a DTI) as shown in Fig. 11:

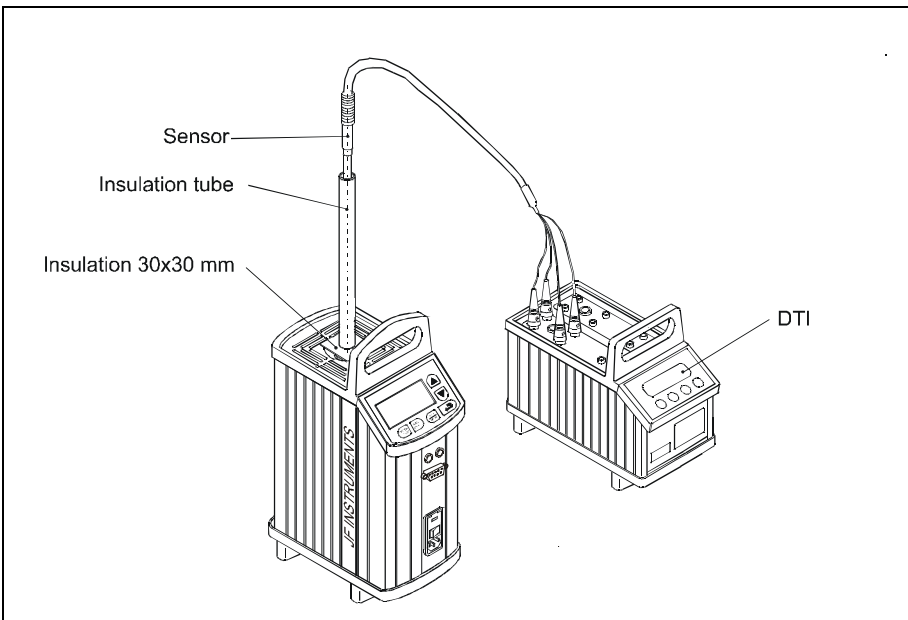





Fig. 11



Hold down the  button while pressing the on/off power control switch.

The instrument is now in adjustment/service mode.



Press  or  to toggle between the different options:

SOFTW.
10



DATE
CAL.



CALIB.
Proc.



SN.
12345





Press  to accept your selection.

To exit the adjustment/service mode, switch the instrument off and on again using the power control switch.



8.2.1 Adjusting the calibration date

Adjust the date by toggling through the available days, months and years. Begin by selecting the required day as shown below:

 Press  or  to select the required day in the interval 1-31.





 Press  to accept your selection.

 Press  or  to select the required month from JAN / FEB / MAR / APR / MAY / JUN / JUL / AUG / SEP / OCT / NOV / DEC.



 Press  to accept your selection.

 Press  or  to select a year between 2001–2025.





Press  to accept your selection. The day will be adjusted if necessary to ensure the legality of the date. Finally, the day, month and year will flash:



Press  to accept the date.

or



press  to cancel the whole selection.

8.2.2 Calibrating/adjusting the instrument

The internal calibration/adjustment is a complex function which is divided into a number of different steps:

The instrument will disclose the first calibration temperature by displaying the text “TEMP.1 XXX°C” for approx. 1 second:

Calibration temperature for calibrators:

MTC-140 A	1.	-15°C / 5°F
	2.	20°C / 68°F
	3.	60°C / 140°F
	4.	100°C / 212°F
	5.	140°C / 284°F

- MTC-320 A
1. 50°C / 122°F
 2. 120°C / 248°F
 3. 180°C / 356°F
 4. 250°C / 482°F
 5. 320°C / 608°F

- MTC-650 A
1. 50°C / 122°F
 2. 200°C / 392°F
 3. 350°C / 662°F
 4. 500°C / 932°F
 5. 650°C / 1202°F

The instrument will now heat up/cool down to reach the first calibration temperature:

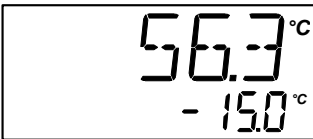

Once the calibrator is stable, you need to enter the reference temperature found using the reference thermometer. The calibration temperature is suggested as a reference point:

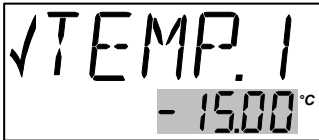

This procedure is repeated for TEMP.2, TEMP.3, TEMP.4 and TEMP.5.

All five calibration temperatures and associated reference temperatures have now been entered.

The instrument will now check whether the reference temperatures which have been entered are within the permitted tolerances.

Permitted tolerances:

- MTC-140 A, MTC-320 A: $\pm 0,15^{\circ}\text{C}$ / 0.27°F
- MTC-650 A: $\pm 0,25^{\circ}\text{C}$ / 0.45°F



If the instrument detects excessive deviations for one or more steps, it will show a screen reading =ERR. in the top of the display. The text Adj. will flash in the bottom of the display to indicate that an

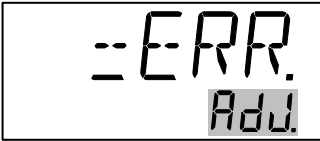

adjustment is required (accept by pressing ):

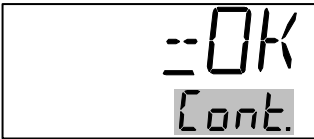



If the calibrator is found to be within the permitted tolerances, the instrument will display the text =OK at the top of the display. The text Cont. will flash in the bottom of the display to indicate that you may continue without adjustments:



 Press  to cancel the adjustment function.



 Press  to go back to a previous screen and press  to repeat an adjustment step when it is shown on the display.



 Press  to toggle between Adj. and Cont. on the display.

 Press  when Adj. is flashing to calculate a new set of coefficients. Next, repeat the entire calibration/adjustment procedure.

If the new coefficients deviate by more than 4% from the standard values, the instrument will display an ERROR 2 in the display. The calculated coefficients will be ignored:



 Press  to repeat the entire calibration/adjustment procedure.

 Press  when Cont. is flashing to end the calibration/adjustment procedure and enter a new calibration date (see section 8.2.1).

9.0 Technical specifications

The illustration below shows the setup which forms the basis for the technical specifications.

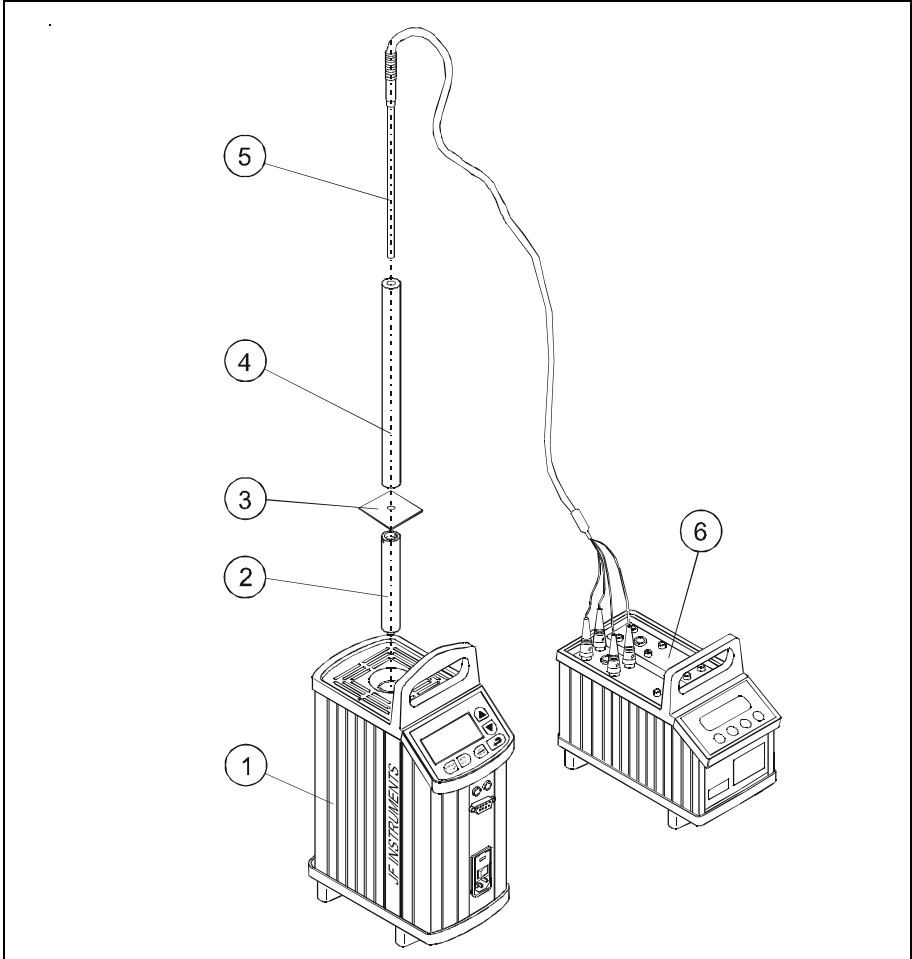

Fig: 12

Pos.	Description
①	Calibrator
②	Ø4.2 mm insertion tube
③	Insulation 30 x 30 mm
④	Insulation tube for Ø4 mm sensor
⑤	Ø4 mm Pt 100 sensor with traceable certificate
⑥	DTI 1000 reference precision thermometer with traceable certificate

Thermal specifications ¹

¹ All specifications are given with an ambient temperature of 23°C/73.4°F ± 3°C/5.4°F

² Specified at 115V / 230V

Specifications	Model
	MTC-140 A
Max. Temperature :	140°C / 284°F
Min. Temperature :	-30°C / -22°F @ ambient temperature 0°C / 32°F -17°C / 1°F @ ambient temperature 23°C / 73°F -2°C / 28°F @ ambient temperature 40°C / 104°F
Display resolution :	0.1°C / 0.1°F
Stability :	±0.05°C / ±0.09°F
Accuracy *	
12 months :	±0.4°C / ±0.72°F
36 months :	±0.8°C / ±1.44°F

Specifications	Model
Heating, ² 23°C to max.	: 15 min.
Time to stability	: 5 min.
Cooling, max. to min.	: 25 min.
MTC-320 A	
Max. Temperature :	320°C / 608°F
Min. Temperature :	33°C / 91°F @ ambient temperature 23°C / 73°F
Display resolution :	0.1°C / 0.1°F
Stability :	±0.1°C / ±0.18°F
Accuracy *	
12 months :	±0.5°C / ±0.9°F
36 months :	±1.2°C / ±2.16°F
Heating, ² 23°C to max.	: 4 min.
Time to stability	: 8 min.
Cooling, max. to min.	: 29 min.
MTC-650 A	
Max. Temperature :	650°C / 1202°F
Min. Temperature :	33°C / 91°F @ ambient temperature 23°C / 73°F
Display resolution :	0.1°C / 0.1°F
Stability :	±0.1°C / ±0.18°F
Accuracy *	
12 months :	±0.9°C / ±1.62°F
36 months :	±1.8°C / ±3.24°F

Specifications	Model
Heating, ² 23°C to max.	: 10 min.
Time to stability	: 8 min.
Cooling, max. to min.	: 44 min.

* Accuracy : Drift over time depends on actual use, environment and handling. The specified 1 year and 3 year accuracy includes typical drift based on 70 calibrations pr. year at maximum temperature for 1 hour.

Electrical specifications

Specifications	Model
	MTC-140 A
Power supply [VAC], 115VAC, 45-65Hz :	90-127
230VAC, 45-65Hz :	180-254
Power consumption, [VA] :	150
Test voltage, switch test [V] :	5
	MTC-320 A
Power supply [VAC], 115VAC, 45-65Hz :	90-127
230VAC, 45-65Hz :	180-254
Power consumption, [VA] :	1150
Test voltage, switch test [V] :	5

Specifications	Model
	MTC-650 A
Power supply [VAC], 115VAC, 45-65Hz :	90-127
230VAC, 45-65Hz :	180-254
Power consumption, [VA] :	1150
Test voltage, switch test [V] :	5

Mechanical specifications

Specifications	Model
	MTC-140 A
Weight :	6.5 Kg. / 14.3 Lbs.
Dimensions HxWxL :	325 x 139 x 241 mm / 12.80 x 5.47 x 9.49 inch
Operating temp. :	0 - 40°C / 32 - 104°F
Storage temp. :	-20 - 50°C / -4 - 122°F
Humidity range :	0-90% Rh
Protection class :	IP10
Electromagnetic environment :	Designed for use in basic and industrial electromagnetic environment as defined in EN61326-1 : 2013
	MTC-320 A
Weight :	5.0 Kg. / 11.0 Lbs.
Dimensions HxWxL :	325 x 139 x 241 mm / 12.80 x 5.47 x 9.49 inch.

Specifications	Model
Operating temp. :	0 - 40°C / 32 - 104°F
Storage temp. :	-20 - 50°C / -4 - 122°F
Humidity range :	0-90% Rh
Protection class :	IP10
Electromagnetic environment :	Designed for use in basic and industrial electromagnetic environment as defined in EN61326-1 : 2013
	MTC-650 A
Weight :	6.4 Kg. / 14.1 Lbs.
Dimensions HxWxL :	325 x 139 x 241 mm / 12.80 x 5.47 x 9.49 inch.
Operating temp. :	0 - 40°C / 32 - 104°F
Storage temp. :	-20 - 50°C / -4 - 122°F
Humidity range :	0-90% Rh
Protection class :	IP10
Electromagnetic environment :	Designed for use in basic and industrial electromagnetic environment as defined in EN61326-1 : 2013

Additional data - directives observed

The following standards are observed according to the EMC-Directive (2014/30/EU)

EN 61326-1: 2013: Electrical equipment for measurement, control and laboratory use – EMC requirements.

The following standards are observed according to the low voltage-directive (2014/35/EU)

EN61010-1:2010 : Safety requirements for electrical equipment for measurement, control and laboratory use, part 1: General requirement

EN61010-2-030:2010 : Safety requirements for electrical equipment for measurement, control and laboratory use, part 2-03: Particular requirements for testing and measuring circuits

Approvals

Approved by “Det Norske Veritas” DNV.

10.0 List of accessories

All parts listed in the list of accessories can be obtained from the factory through our dealers.

Please contact your dealer for assistance if you require parts which do not appear on the list.

List of accessories

Accessories	Parts no.
Fuse 115V, 10AF (MTC-320/650 A)	60B302
Fuse 230V, 5AF (MTC-320/650 A)	60B301
Fuse 115V, 2AT (MTC-140 A)	105014
Fuse 230V, 1AT (MTC-140 A)	105007
Reference manual	105337
Tool for insertion tube	60F170
Heat protection shield	104216
Alu. carrying case, high	123408
Mains cable, 115V, US, type B	60F135
Mains cable, 240V, UK, type C	60F136
Mains cable, 220V, South Africa, type D	60F137
Mains cable, 220V, Italy, type E	60F138
Mains cable, 240V, Australia, type F	60F139
Mains cable, 230V, Europe, type A	60F140
Mains cable, 230V, Denmark, type G	60F141
Mains cable, 220V, Switzerland, type H	60F142
Mains cable, 230V, Israel, type I	60F143
Insulation tube, 100 mm	65-F100
Insulation tube, 150 mm	65-F101
Insulation tube, 200 mm	65-F102
Insulation tube, 250 mm	65-F103

List of accessories

Accessories	Parts no.
Insulation tube, 300 mm	65-F104
Insulation tube, 350 mm	65-F105
Insulation tube, 400 mm	65-F106
Insulation tube, 450 mm	65-F107
Insulation 30 x 30 mm	105173
Cleaning brush, 4 mm	122832
Cleaning brush, 6 mm	60F174
Cleaning brush, 8 mm	122822
Set of insulation plugs (MTC-140 A only)	123469
Set of test cables	104203
RS232 serial cable	105366
JofraCal PC software	124915
Certificate, National	99-C-T

11.0 Standard insertion tubes



Caution...

To get the best results out of your calibrator, the insertion tube dimensions, tolerance and material are critical. We highly advise using the JOFRA insertion tubes, as they guarantee trouble free operation. Use of other insertion tubes may reduce performance of the calibrator and cause the insertion tube to get stuck.

PARTS NO. FOR STANDARD INSERTION TUBES			
Sensor size	MTC-140 A	MTC-320 A	MTC-650 A
undrilled	60F448	100175	100194
1/8"	60F450	100176	100195
3/16"	60F452	100178	100197
1/4"	60F454	100180	100199
5/16"	60F456	100181	100200
3/8"	60F458	100184	100203
7/16"	60F460	100187	100205
1/2"	60F462	100189	100207
9/16"	60F464	60F344	60F408
5/8"	60F466	100192	100210
11/16"	-	60F348	60F412
13/16"	-	60F352	60F416
3/4"	-	100193	100211
7/8"	-	60F354	60F418

PARTS NO. FOR STANDARD INSERTION TUBES			
Sensor size	MTC-140 A	MTC-320 A	MTC-650 A
3 mm	123428	123436	123444
4 mm	60F451	100177	100196
5 mm	123429	123437	123445
6 mm	60F453	100179	100198
7 mm	123430	123438	122516
8 mm	105185	100182	100201
9 mm	105186	100183	100202
10 mm	105187	100185	105188
11 mm	123431	100188	100204
12 mm	123432	100186	100206
13 mm	123433	60F339	105189
14 mm	-	100190	100208
15 mm	-	100191	100209
16 mm	-	123439	123446
18 mm	-	123440	122517
20 mm	-	123441	122518

PART NO. FOR STANDARD INSERTION TUBES – MULTI-HOLE			
Description	MTC-140 A	MTC-320 A	MTC-650 A
Metric Type 1	123479	123475	123476
Inch Type 2	123480	123477	123478

Note: All multi-hole insertion tubes are delivered with a matching insulation plug (MTC-140 only).

AMETEK Sensors, Test & Calibration

A business unit of AMETEK Measurement & Calibration Technologies Division offering the following industry leading brands for test and calibration instrumentation.

JOFRA Calibration Instruments

Temperature Calibrators

Portable dry-block calibrators, precision thermometers and liquid baths. Temperature sensors for industrial and marine use.

Pressure Calibrators

Convenient electronic systems ranging from -25 mbar to 1000 bar - fully temperature-compensated for problem-free and accurate field use.

Signal Instruments

Process signal measurement and simulation for easy control loop calibration and measurement tasks.

M&G Deadweight Testers & Pumps

Pneumatic floating-ball or hydraulic piston dead weight testers with accuracies to 0.015% of reading. Pressure generators delivering up to 1,000 bar.

Crystal Pressure

Digital pressure gauges and calibrators that are accurate, easy-to-use and reliable. Designed for use in the harshest environments; most products carry an IS, IP67 and DNV rating.

Lloyd Materials Testing

Materials testing machines and software that guarantees expert materials testing solutions. Also covering Texture Analysers to perform rapid, general food testing and detailed texture analysis on a diverse range of foods and cosmetics.

Davenport Polymer Test Equipment

Allows measurement and characterization of moisture-sensitive PET polymers and polymer density.

Chatillon Force Measurement

The hand held force gauges and motorized testers have earned their reputation for quality, reliability and accuracy and they represent the de facto standard for force measurement.

Newage Hardness Testing

Hardness testers, durometers, optical systems and software for data acquisition and analysis.



www.ametekcalibration.com

United Kingdom

Tel +44 (0)1243 833 302
caluk.sales@ametek.com

France

Tel +33 (0)1 30 68 89 40
general.lloyd-instruments@ametek.fr

Germany

Tel +49 (0)2159 9136 510
info.mct-de@ametek.de

Denmark

Tel +45 4816 8000
jofra@ametek.com

USA

Florida
Tel +1 (800) 527 9999
cal.info@ametek.com

California

Tel +1 (800) 444 1850
crystal@ametek.com

India

Tel +91 22 2836 4750
jofra@ametek.com

Singapore

Tel +65 6484 2388
jofra@ametek.com

China

Shanghai
Tel +86 21 5868 5111

Beijing

Tel +86 10 8526 2111
jofra.sales@ametek.com.cn